



Rewarding Learning

General Certificate of Secondary Education
2022

Centre Number

--	--	--	--	--

Candidate Number

--	--	--	--

Further Mathematics

Unit 2 (With calculator)

Mechanics



MV18

[GFM21]

TUESDAY 21 JUNE, MORNING

Time

1 hour, plus your additional time allowance.

Instructions to Candidates

Write your Centre Number and Candidate Number in the spaces provided at the top of this page.

You must answer the questions in the spaces provided.

Complete in black ink only.

All working **must** be clearly shown in the spaces provided.

Marks may be awarded for partially correct solutions.

Where rounding is necessary give answers correct to **2 decimal places** unless stated otherwise. Take $g = 10 \text{ m/s}^2$ when required.

Answer **all six** questions.

Information for Candidates

The total mark for this paper is 50.

Figures in brackets printed at the end of each question indicate the marks awarded to each question or part question.

You may use a calculator. The Formula Sheet is on page 2.

Formula Sheet

Mechanics

Quadratic equations: If $ax^2 + bx + c = 0$ ($a \neq 0$)

$$\text{then } x = \frac{-b \pm \sqrt{b^2 - 4ac}}{2a}$$

Vectors: Magnitude of $x\mathbf{i} + y\mathbf{j}$ is given by $\sqrt{x^2 + y^2}$
Angle between $x\mathbf{i} + y\mathbf{j}$ and \mathbf{i} is given by $\tan^{-1}\left(\frac{y}{x}\right)$

Uniform Acceleration: $v = u + at$

$$v^2 = u^2 + 2as$$

$$s = \frac{1}{2}(u + v)t$$

$$s = ut + \frac{1}{2}at^2$$

where u is initial velocity
 v is final velocity
 a is acceleration
 t is time
 s is change in displacement

Newton's Second Law: $F = ma$

where F is resultant force
 a is acceleration
 m is mass

Blank Page
(Questions start overleaf)

- 1 Complete the table below by ticking if each measure given in the table is a vector or a scalar. [2 marks]

Measure	Vector	Scalar
Mass		
Speed		
Time		
Tension		

2 (Throughout this question **i** and **j** denote unit vectors parallel to a set of standard x - y axes.)

Two forces **p** and **q** are defined by

$$\mathbf{p} = (-3\mathbf{i} - 5\mathbf{j}) \text{ N} \quad \text{and} \quad \mathbf{q} = (-6\mathbf{i} + 3\mathbf{j}) \text{ N}.$$

(i) Find the resultant **R** of the forces **p** and **q**. [2 marks]

Answer _____ N

(ii) Calculate the magnitude of the resultant **R**. [2 marks]

Answer _____ N

- 3 (a) A box of mass 6 kg is pulled in a straight line along a **rough**, horizontal plane by a light, inextensible string.

The string is held parallel to the plane, as shown in the diagram below.



The tension in the string is 33 N.

The force due to friction is 4 N per kg of mass.

The box moves with constant acceleration.

Show that the acceleration of the box is 1.5 m/s^2
[2 marks]

(b) A **different** box, of mass 8 kg, is pulled along the same rough, horizontal plane by another light, inextensible string inclined at an angle of 35° to the horizontal, as shown in the diagram below.

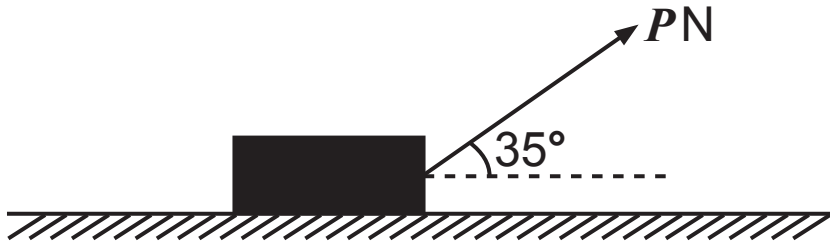

The force due to friction is 4 N per kg of mass.

The string exerts a force of P newtons on the box.

(i) Mark, on the diagram above, all the other forces acting on the block. [2 marks]

The box moves with an acceleration of 1.5 m/s^2

(ii) Calculate the value of P . [3 marks]

Answer _____

- 4 Grace is driving her car along a straight, horizontal road at 25 m/s when she sees the following sign:

Roadworks 350 m Ahead

As she passes the sign, she applies the brakes and decelerates at 1.8 m/s^2 for 8 seconds to reach a velocity of $V \text{ m/s}$.

Grace then travels at this velocity $V \text{ m/s}$ for 10 seconds.

She brakes again so that her car decelerates uniformly to come to rest just as it reaches the roadworks.

This is illustrated by the velocity–time graph shown below.

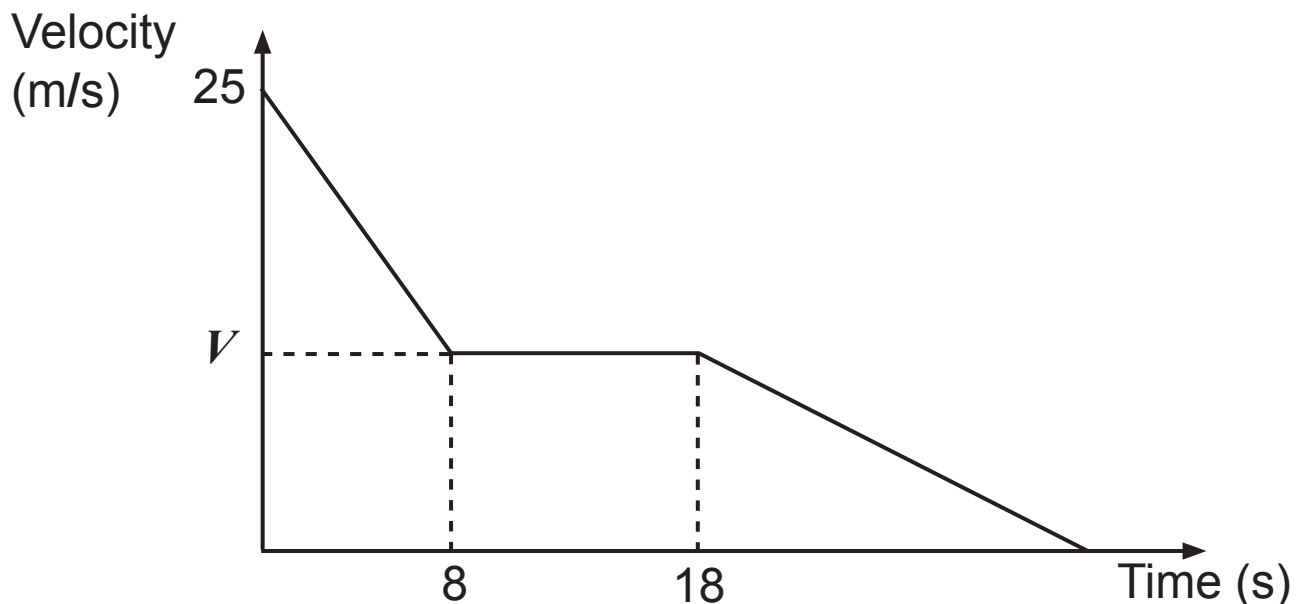

(i) Calculate the value of V . [2 marks]

Answer _____

(ii) Calculate the distance travelled in the first 18 seconds. [4 marks]

Answer _____ m

(iii) Calculate the **total** time for the car to travel the 350 metres to reach the roadworks. [4 marks]

Answer _____ s

- 5 Two blocks, A and B, of masses 6.3 kg and 3.7 kg respectively, are connected by a light, inextensible string that passes over a smooth pulley which is attached to a ceiling.

The blocks are held at a distance of 1.2 m above horizontal ground, as shown in the diagram below.

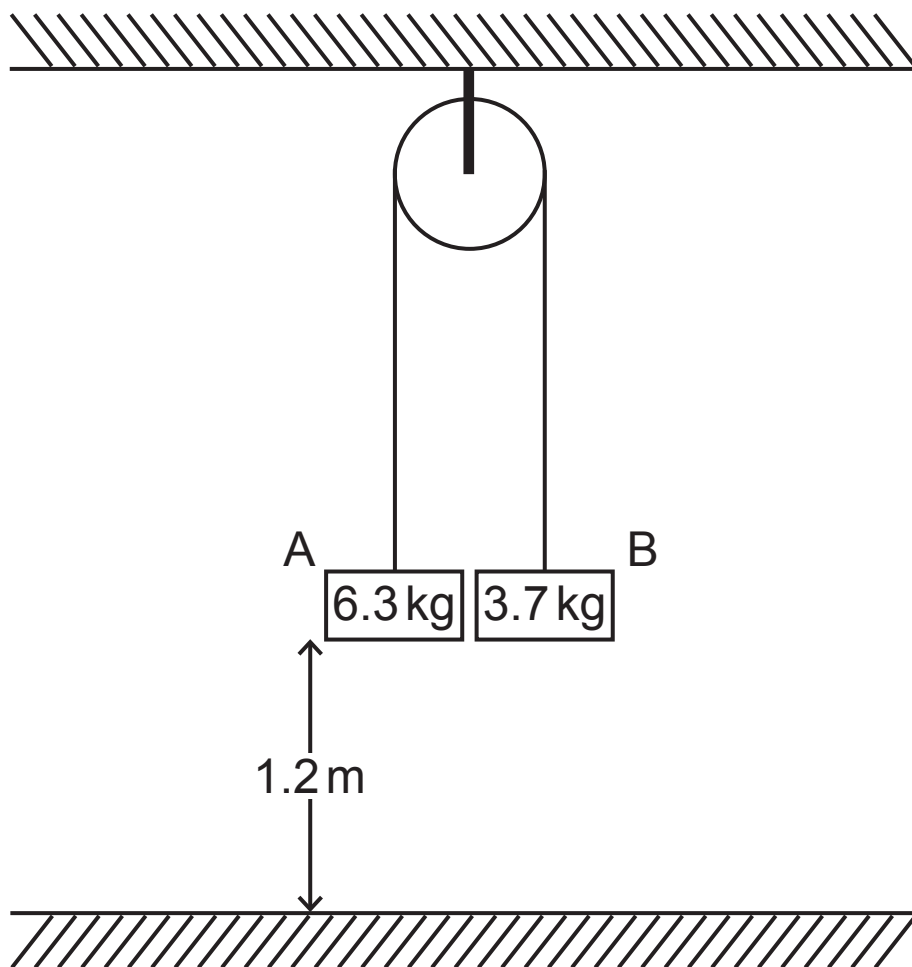

The blocks are released from rest.

- (i) Mark, on the diagram above, all the forces acting on the blocks. [2 marks]

While the blocks are in motion, calculate

(ii) the acceleration of the blocks, [3 marks]

Answer _____ m/s^2

(iii) the tension in the string, [2 marks]

Answer _____ N

(iv) the force acting on the pulley. [1 mark]

Answer _____ N

After the blocks are released from rest, block A hits the ground.

Assuming that block B doesn't hit the pulley, calculate

(v) the speed with which block A hits the ground,
[2 marks]

Answer _____ m/s

(vi) the maximum height above the ground reached by block B. [3 marks]

Answer _____ m

- 6 A uniform rod AB rests horizontally on two smooth pivots at the points A and C.

The rod is of length 5 m and mass 12 kg.

The distance BC is 1.5 m, as shown in the diagram below.



A mass of M kg is attached to the rod at B so that the rod remains horizontal and in equilibrium.

The reaction at the pivot at C is three times the reaction at the pivot at A.

- (i) Mark, on the diagram above, all the forces acting on the rod. [2 marks]

(ii) By taking moments about B, calculate the reaction at the pivot at C. [5 marks]

Answer _____ N

(iii) Calculate the value of M . [2 marks]

Answer _____

The mass of M kg at B is now removed and a mass of 6 kg is placed on the rod at the point D, where the distance AD is x metres, as shown in the diagram below.



The rod remains horizontal and in equilibrium.

The reactions at A and C are now equal in magnitude.

(iv) Calculate the value of x . [5 marks]

Answer _____

This the end of the question paper

For Examiner's use only	
Question Number	Marks
1	
2	
3	
4	
5	
6	

Total Marks	
--------------------	--

Examiner Number

Permission to reproduce all copyright material has been applied for. In some cases, efforts to contact copyright holders may have been unsuccessful and CCEA will be happy to rectify any omissions of acknowledgement in future if notified.